

SINGER

5100 Series

SINGER*

Sub Classes

**LIST OF PARTS FOR
SEWING MACHINES**

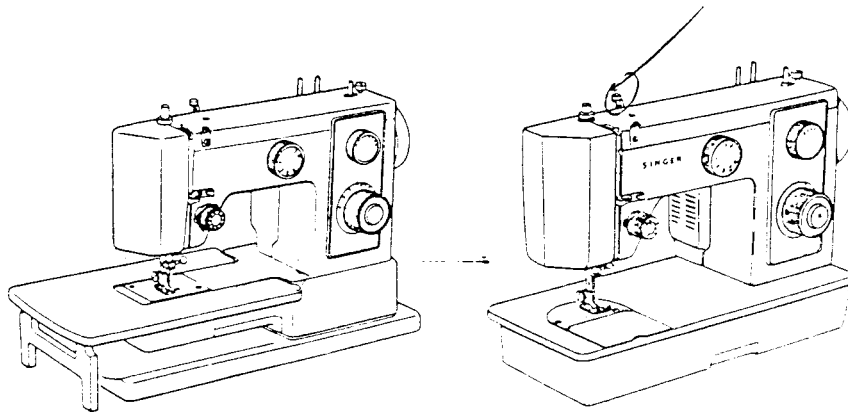

5100 SERIES

Copyright © 1980 THE SINGER COMPANY
All Rights Reserved Throughout the World



*A Trademark of THE SINGER COMPANY

TABLE OF TERRITORIES

COUNTRY	MOTOR	CONTROLLER WITH LABEL	LIGHT HARNESS
U. S. A.	988215-001 988236-001 (ALT.) (120 V)	988216-001 (120 V)	988279-001
	988217-001	988218-001	
CANADA	988215-001 988236-001 (ALT.) (120 V)	988295-001 (120 V)	988279-001
	988217-001	988218-001	
YUGOSLAVIA, IRAN, NEW ZEALAND, SOUTH AFRICA, ISRAEL, GERMANY, AUSTRIA, FRANCE, ITALY, PORTUGAL, GREECE	988217-002 (220 V)	988218-002 (220 V)	988227-001
NETHERLAND, BELGIUM, SWITZERLAND	988217-002 (220 V)	988218-002 (220 V)	988227-001
UNITED KINGDOM	988217-003 (240 V)	988218-004 (240 V)	988227-001
AUSTRALIA	988217-003 (240 V)	988218-005 (240 V)	988227-001
GERMANY	988217-002 (220 V)	988218-002 (220 V)	988227-001
EUROPE-NON MANDATORY	988217-002 (220 V)	988218-002 (220 V)	988227-001
AUSTRIA	988217-002 (220 V)	988218-002 (220 V)	988227-001
DENMARK	988217-002 (220 V)	988218-003 (220 V)	988227-001
SWEDEN, NORWAY, FINLAND	988217-002 (220 V)	988218-002 (220 V)	988227-001

<u>MECHANISM DESCRIPTION</u>	<u>PAGE</u>
ATTACHMENT SET	4
MACHINE COVERS	5
SELECTOR DIALS AND PANELS	8
SHUTTLE AND SHUTTLE DRIVE ASSEMBLIES	9
FEED MECHANISM	12
HEAD END MECHANISM	13
ARM SHAFT AND NEEDLE THREAD TENSION ASSEMBLIES	16
CAM CONTROL MECHANISM	17, 20, 21
ELECTRICAL EQUIPMENT	24

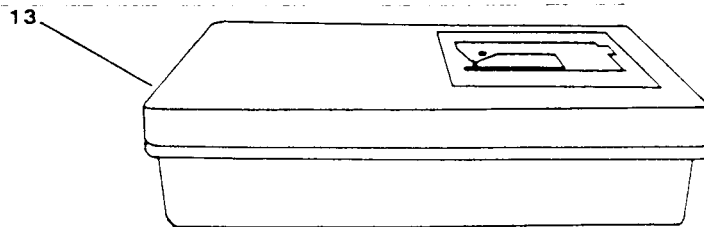
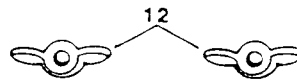
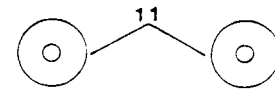
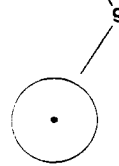
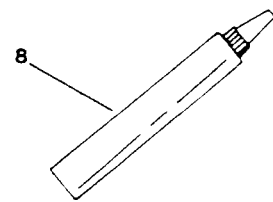
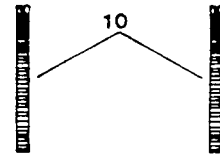
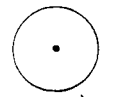
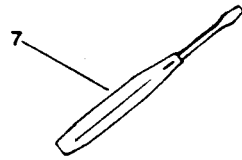
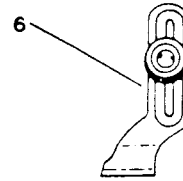
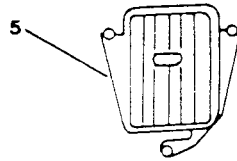
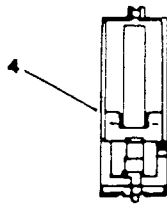
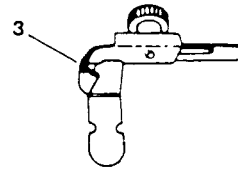
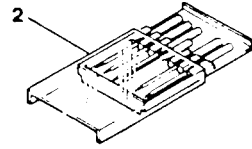
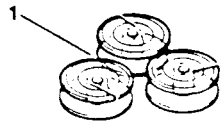

5100 SERIES

MACHINE COVERS

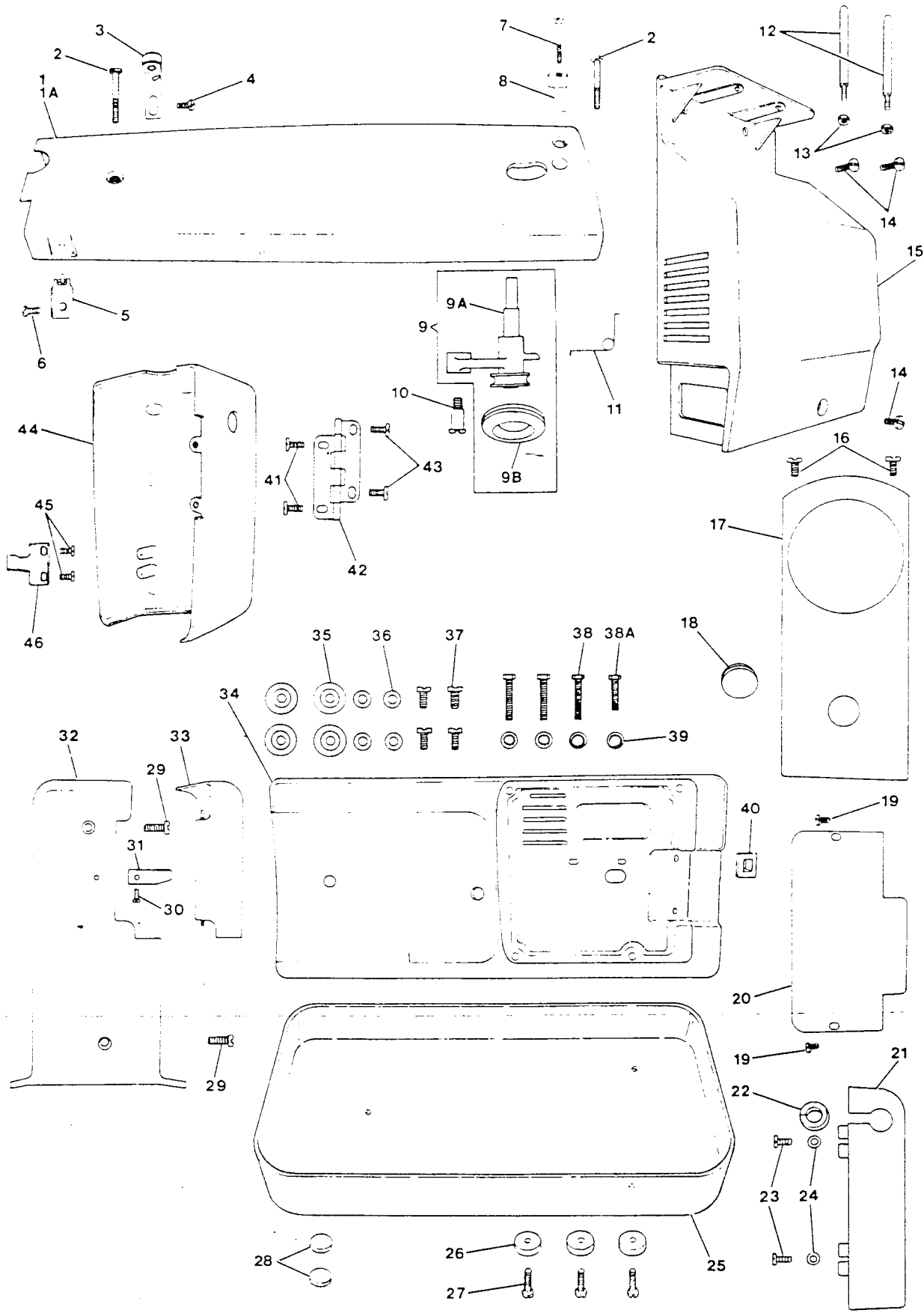

From the library of: Diamond Needle Corp

5100 PARTS LIST

REF.	PART #	MACHINE COVERS	5102	5107	5123	5127
1A	170395-001	Arm top cover	X		X	
1	170395	Arm top cover		X		X
2	170392	Upper plate set screw (2)	X	X	X	X
3	170396	Thread guide (rear) >	X	X	X	X
4	170396-001	Thread guide screw	X	X	X	X
5	170397	Upper thread guide >	X	X	X	X
6	170539	Thread guide screw	X	X	X	X
7	170393	Set screw	X	X	X	X
8	170394	Bobbin winder stopper	X	X	X	X
9	170243	Bobbin winder complete	X	X	X	X
9A	170243-001	Bobbin winder bracket	X	X	X	X
9B	170520	Bobbin winder ring	X	X	X	X
10	170244	Bobbin winder bracket screw	X	X	X	X
11	170245	Bobbin winder frame spring	X	X	X	X
12	170541	Spool pin	X	X	X	X
13	170542	Spool pin nut	X	X	X	X
14	170432	Set screw (3)	X	X	X	X
15	170431	Motor cover with spool pin	X	X	X	X
16	170410	Set screw (2)	X	X	X	X
17	170411	Rear arm cover	X	X	X	X
18	170351	Plastic filler plug (large)			X	X
19	170426	Set screw (2)			X	X
20	170425	Rear bed cover			X	X
21	170510	Bed extension plate	X	X		
22	170511	Bed extension plate grommet	X	X		
23	170513	Set screw	X	X		
24	170512	Washer	X	X		
25	170508	Bottom cover	X	X		
26	170514	Bottom cover cushion (large) (3)	X	X		
27	170515	Set screw (2)	X	X		
28	170509	Bottom cover cushion (small) (2)	X	X		
29	170377	Set screw (2)			X	X
30	170375	Set screw			X	X
31	170374	Spring			X	X
32	170376	Button plate			X	X
33	170373	Shuttle race cover			X	X
34	170378	Base			X	X
35	170381	Rubber protector (4)			X	X
36	170380	Washer (4)			X	X
37	170382	Set screw (4)			X	X
38	170543	Base screw (long) (3)	X	X	X	X
38A	170544	Base screw (short)	X	X	X	X
39	170545	Base screw washer (4)	X	X	X	X
40	170379	Base grommet			X	X
41	170404	Set screw (2)	X	X	X	X
42	170403	Face plate hinge	X	X	X	X
43	170405	Set screw (2)	X	X	X	X
44	170400	Face cover	X	X	X	X
45	170402	Set screw (2)	X	X	X	X
46	170401	Face cover spring	X	X	X	X

5100 PARTS LIST

REF.	PART #	SELECTOR DIALS AND PANELS	5102	5107	5123	5127
1	170417	Stitch length dial	X			
1A	170417-001	Stitch length dial		X		
1B	170417-002	Stitch length dial			X	X
2	170287	Spring		X	X	X
3	170418	Stitch length dial set screw (2)	X	X	X	X
4	170285	Reverse button	X			
4A	170285-001	Reverse button		X		
4B	170285-002	Reverse button			X	X
5	170286	Set screw	X	X	X	X
6	170420	Pattern selector dial		X		
6A	170420-001	Pattern selector dial			X	
6B	170420-002	Pattern selector dial				X
7	170407	Pattern selector dial set screw (2)	X	X	X	X
8	170406	Stitch width dial	X			
8A	170406-001	Stitch width dial		X		
8B	170406-002	Stitch width dial			X	X
9	170546	Nut	X	X	X	X
10	170547	Stitch width dial set screw (2)	X	X	X	X
11	170409	Control panel			X	X
12	170408	Snap ring			X	X
13	170390	Retaining plate			X	X
14	170391	Set screw			X	X
15	170387	Cloth plate leg			X	X
16	170389	Set screw (2)			X	X
17	170388	Spring (2)			X	X
18	170386	Cloth plate			X	X
19	148844-451	Filler plate			X	X
19A	148845-451	Filler plate			X	X

From the library of: Diamond Needle Corp

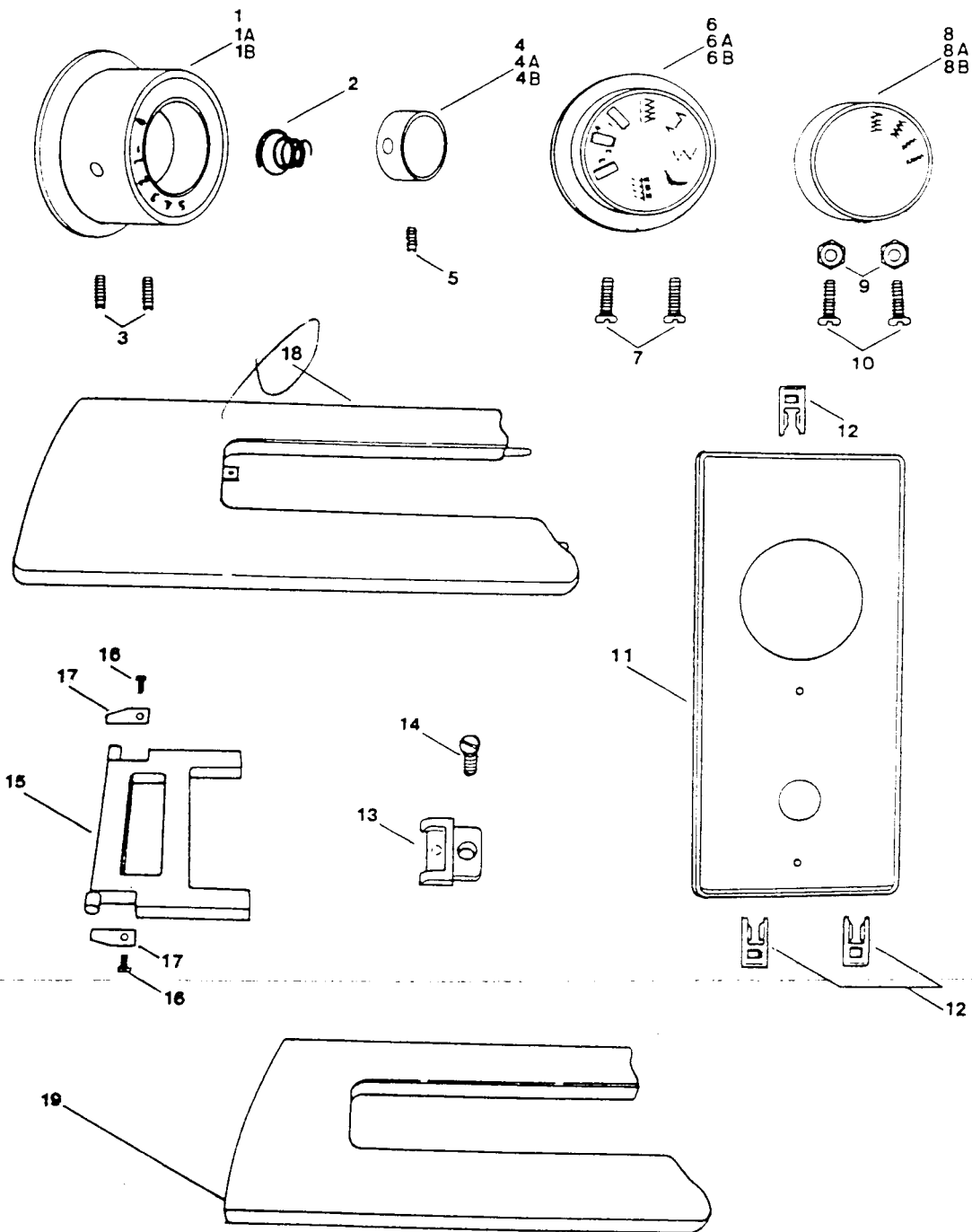

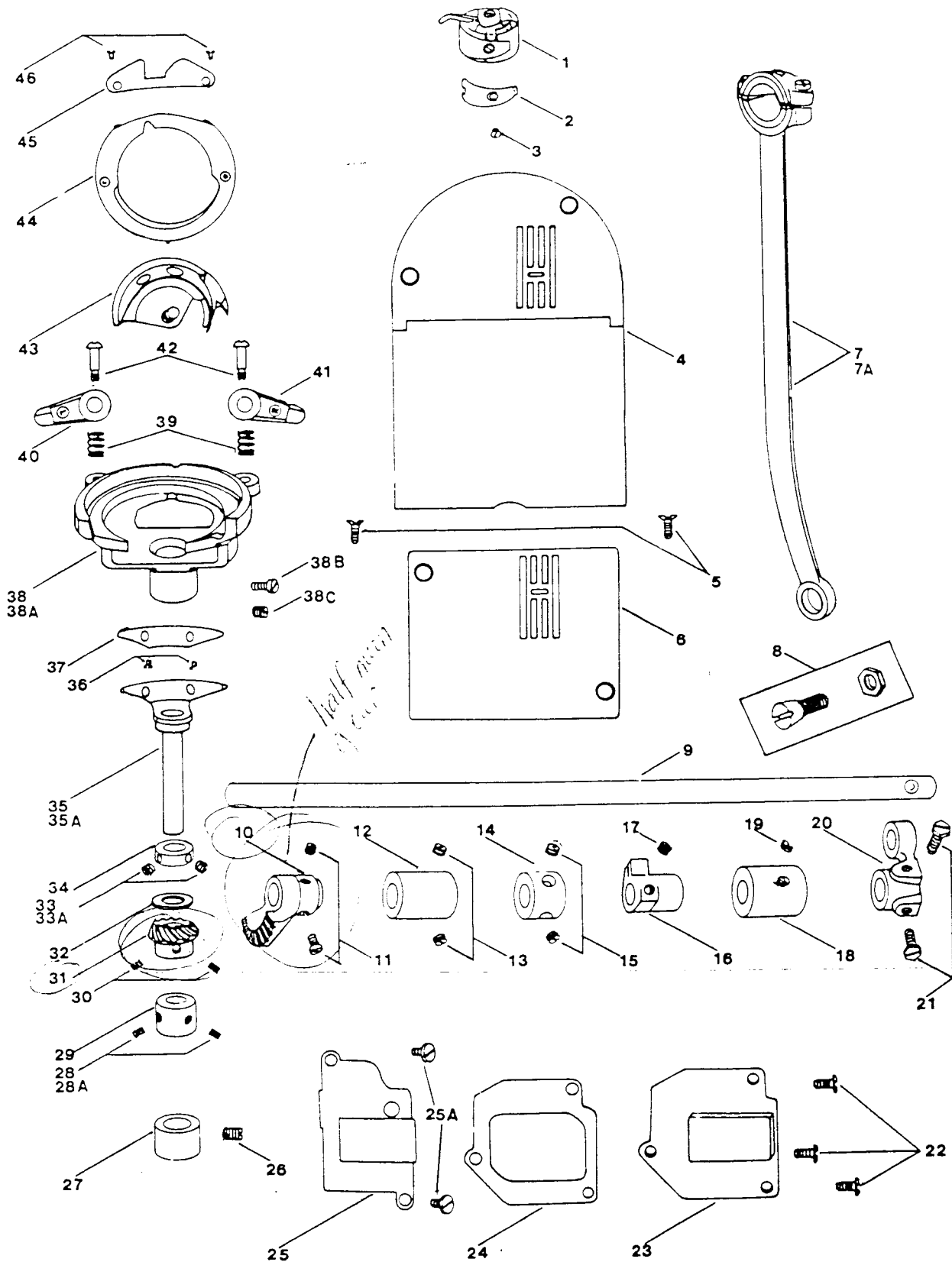

5100 PARTS LIST

REF.	PART #	SHUTTLE/SHUTTLE DRIVE ASSEMBLIES	5102	5107	5123	5127
1	170341	Bobbin case complete	X	X	X	X
2	170518	Tension spring	X	X	X	X
3	170519	Tension spring screw	X	X	X	X
4	170487	Needle & hinged slide plate	X	X		
5	170314	Needle plate screw	X	X	X	X
6	170313	Needle plate			X	X
7	170272	Crank connecting rod			X	X
7A	170506	Crank connecting rod	X	X		
8	170273	Taper screw & nut	X	X	X	X
9	170362	Oscillating shaft	X	X	X	X
10	170352	Gear (large) - <i>half mesh gear</i>	X	X	X	X
11	170355	Gear set screw	X	X	X	X
12	170354	Shaft bushing	X	X	X	X
13	170353	Oscillating shaft bushing set screw (2)	X	X	X	X
14	170356	Oscillating shaft collar	X	X	X	X
15	170357	Oscillating shaft collar set screw (2)	X	X	X	X
16	170358	Oscillating shaft cam	X	X	X	X
17	170359	Oscillating shaft cam set screw	X	X	X	X
18	170361	Oscillating shaft metal	X	X	X	X
19	170360	Oscillating shaft metal set screw	X	X	X	X
20	170363	Oscillating shaft crank	X	X	X	X
21	170364	Set screw (2)	X	X	X	X
22	170494	Set screw for gear box cover (3)	X	X	X	X
23	170495	Gear box cover	X	X		
24	170493	Fiber gasket	X	X		
25	170371	Gear box cover			X	X
25A	170372	Set screw			X	X
26	170486	Set screw	X	X		
27	170485	Shuttle driver shaft	X	X		
28	170348	Shuttle driver shaft collar set screw (2)			X	X
28A	170484	Shuttle driver shaft collar set screw (2)	X	X		
29	170483	Shuttle driver shaft collar	X	X		
30	170350	Set screw	X	X	X	X
31	170349	Gear	X	X	X	X
32	170548	Shuttle driver shaft collar washer	X	X	X	X
33	170348	Shuttle driver shaft collar set screw (2)			X	X
33A	170484	Shuttle driver shaft collar set screw (2)	X	X		
34	170347	Shuttle driver shaft collar			X	X
35	170346	Shuttle driver and shaft			X	X
35A	170482	Shuttle driver and shaft	X	X		
36	170527	Shuttle driver spring screw	X	X	X	X
37	170526	Shuttle driver spring	X	X	X	X
38	170343	Shuttle race			X	X
38A	170481	Shuttle race	X	X		
38B	170549	Shuttle race set screw			X	X
38C	170550	Shuttle race set screw	X	X	X	X
39	170525	Shuttle race latch screw spring (2)	X	X	X	X
40	170551	Shuttle race latch (left)	X	X	X	X
41	170552	Shuttle race latch (right)	X	X	X	X
42	170553	Shuttle race latch screw (2)	X	X	X	X
43	170340	Shuttle	X	X	X	X
44	170554	Shuttle race gate	X	X	X	X
45	170521	Shuttle race cap	X	X	X	X
46	170522	Shuttle race cap screw	X	X	X	X

5100 PARTS LIST

REF.	PART #	FEED MECHANISM	5102	5107	5123	5127
1	170332	Snap ring			X	X
2	170331	Shaft			X	X
3	170327	Feed dog set screw (2)	X	X	X	X
4	170328	Feed dog			X	X
4A	170496	Feed dog	X	X		
5	170329	Feed bracket			X	X
6	170497	Feed bracket	X	X		
7	170365	Feed lifting rock shaft crank			X	X
8	170366	Set screw	X	X		
9	170367	Feed bar crank shaft			X	X
10	170369	Oscillating shaft cam crank			X	X
11	170368	Set screw	X	X	X	X
12	170270	Feed regulator stud	X	X	X	X
13	170269	Feed forked connecting slide block	X	X	X	X
14	170268	Feed forked connection 1			X	X
14A	170504	Feed forked connection	X	X		
15	170271	Feed forked connection			X	X
15A	170505	Taper screw & nut	X	X		
16	170275	Feed adjusting screw	X	X	X	X
17	170276	Nut	X	X	X	X
18	170274	Stitch regulator support plate	X	X	X	X
19	170277	Set screw	X	X	X	X
20	170278	Feed regulator	X	X	X	X
21	170279	Snap ring	X	X	X	X
22	170288	Stitch length mechanism		X	X	X
22A	170507	Stitch length mechanism	X			
23	170289	Set screw	X	X	X	X
24	170498	Oscillating shaft crank	X	X		
25	170370	Spring	X	X	X	X
26	170368	Set screw	X	X	X	X
27	170555	Feed lifting rock shaft	X	X		
28	170556	Crank screw	X	X		
29	170499	Feed lifing rock shaft crank	X	X		
30	170492	Feed rock shaft center screw & nut (2)	X	X		
31	170503	Spring	X	X		
32	170501	Set screw	X	X		
33	170502	Spring plate	X	X		
34	170491	Feed rock shaft	X	X		
35	170500	Feed rock shaft rod crank	X	X		
36	170339	Set screw	X	X	X	X
37	170489	Feed bracket shaft	X	X		
38	170488	Snap ring	X	X		
39	170336	Feed rock shaft center	X	X		
40	170337	Feed rock shaft center	X	X		
41	170335	Set screw	X	X		
42	170334	Feed rock shaft	X	X		
43	170330	Set screw	X	X	X	X
44	170333	Feed bracket spring	X	X		
45	170338	Feed rock shaft crank	X	X		

FEED MECHANISM

5100 SERIES

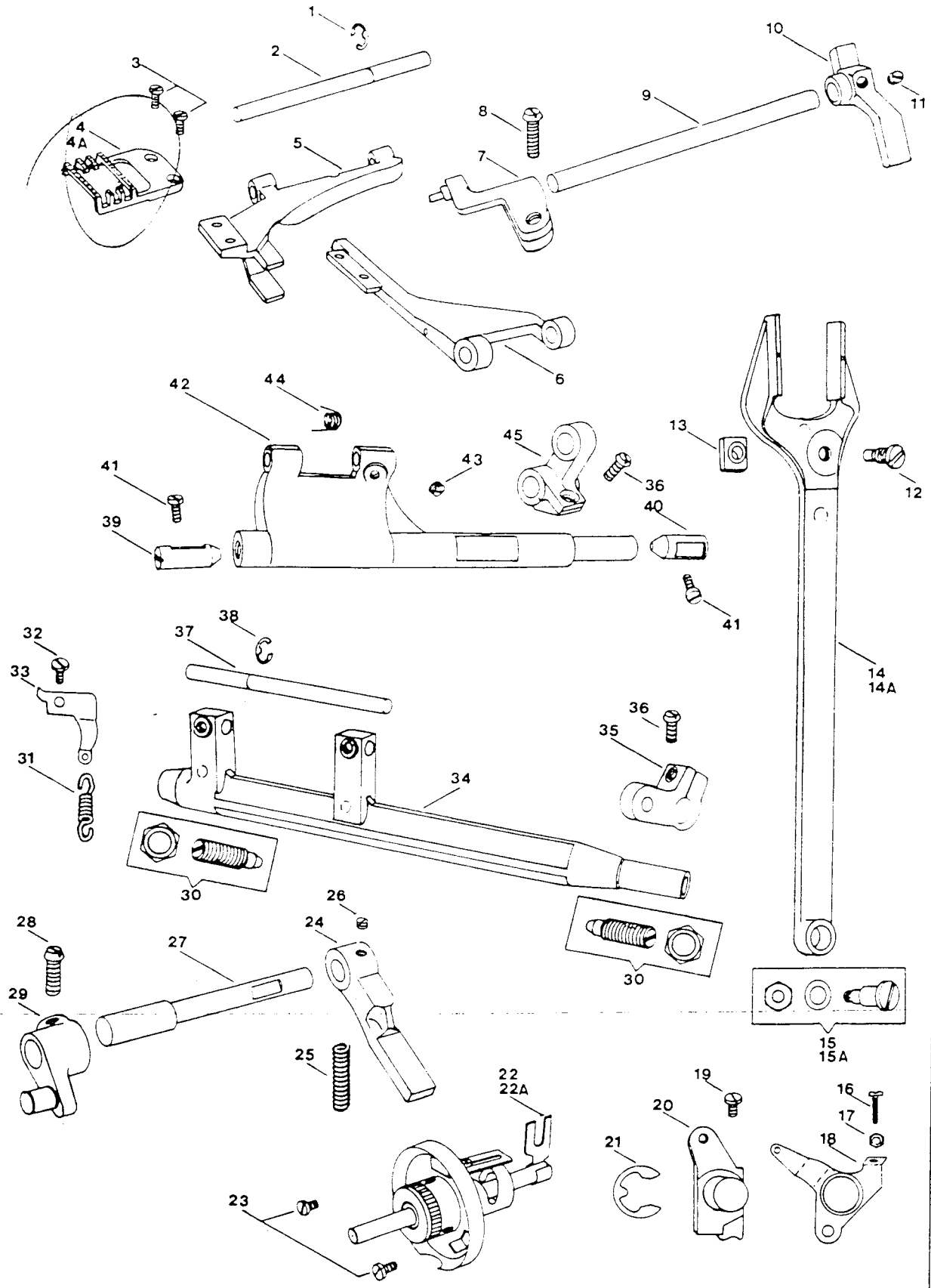

From the library of: Diamond Needle Corp

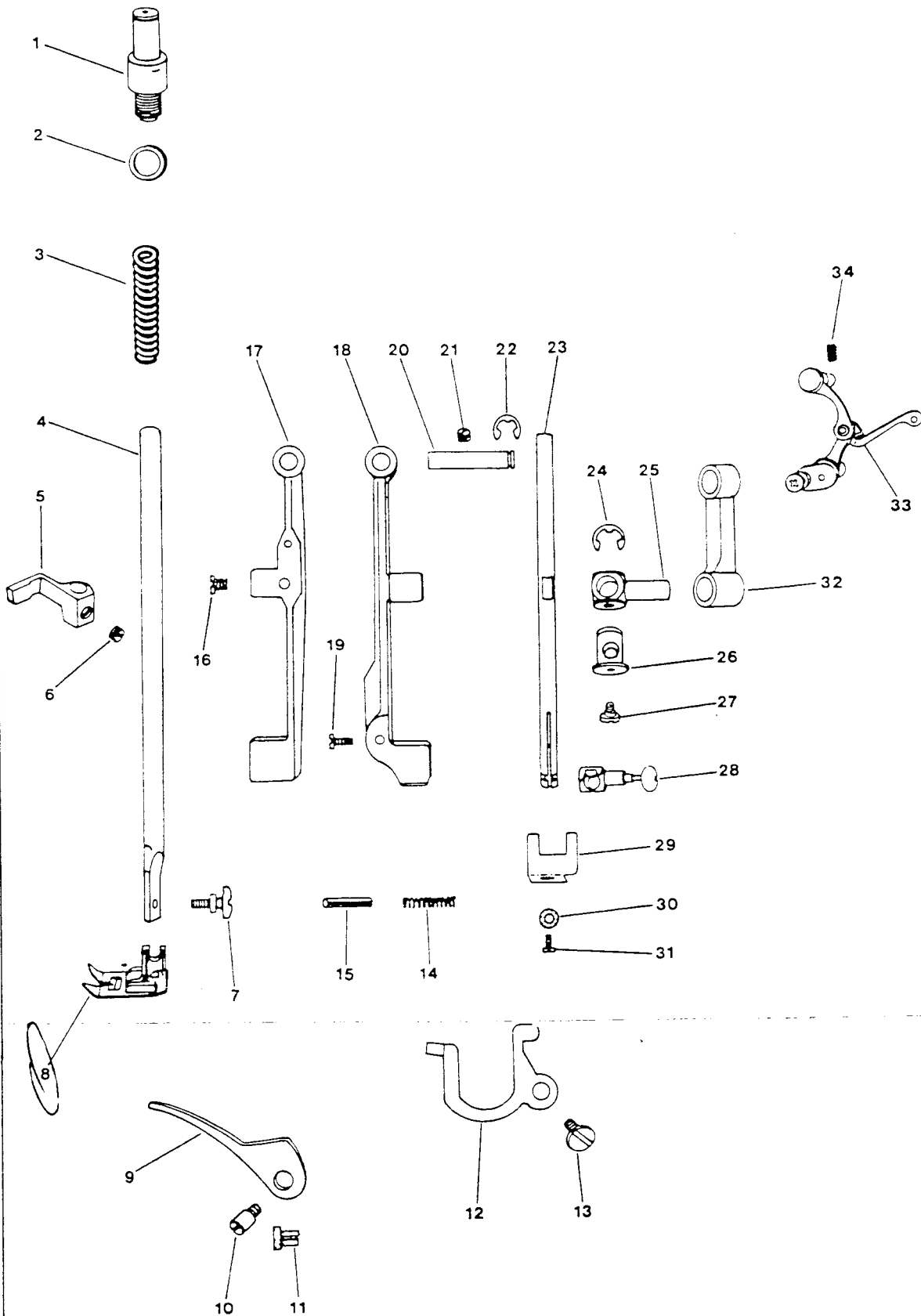

5100 PARTS LIST

REF.	PART #	HEAD END MECHANISM	5102	5107	5123	5127
1	170290	Presser release mechanism	X	X	X	X
2	170557	Presser bar release mechanism washer	X	X	X	X
3	170292	Presser bar spring	X	X	X	X
4	170291	Presser bar	X	X	X	X
5	170294	Presser bar slide	X	X	X	X
6	170295	Set screw	X	X	X	X
7	170293	Presser foot set screw	X	X	X	X
8	170323	Presser foot	X	X	X	X
9	170296	Presser bar lifter	X	X	X	X
10	170297	Presser bar lifter hinge stud	X	X	X	X
11	170304	Presser bar lifter cushion	X	X	X	X
12	170300	Tension release lever	X	X	X	X
13	170301	Tension release lever set screw	X	X	X	X
14	170318	Spring	X	X	X	X
15	170319	Set pin	X	X	X	X
16	170317	Set screw	X	X	X	X
17	170316	Needle bar supporter		X	X	X
18	170480	Needle bar supporter	X			
19	170558	Needle bar supporter screw			X	X
20	170307	Needle bar supporter shaft	X	X	X	X
21	170305	Needle bar supporter shaft set screw	X	X	X	X
22	170306	Snap ring	X	X	X	X
23	170320	Needle bar	X	X	X	X
24	170308	Snap ring	X	X	X	X
25	170326	Needle bar holder	X	X	X	X
26	170309	Needle bar supporter pin		X	X	X
27	170325	Set screw	X	X	X	X
28	170321	Needle clamp	X	X	X	X
29	170310	Needle bar bracket stop	X	X	X	X
30	170311	Washer	X	X	X	X
31	170312	Set screw	X	X	X	X
32	170324	Needle bar crank	X	X	X	X
33	170204	Thread take-up lever	X	X	X	X
34	170205	Thread take-up lever screw	X	X	X	X

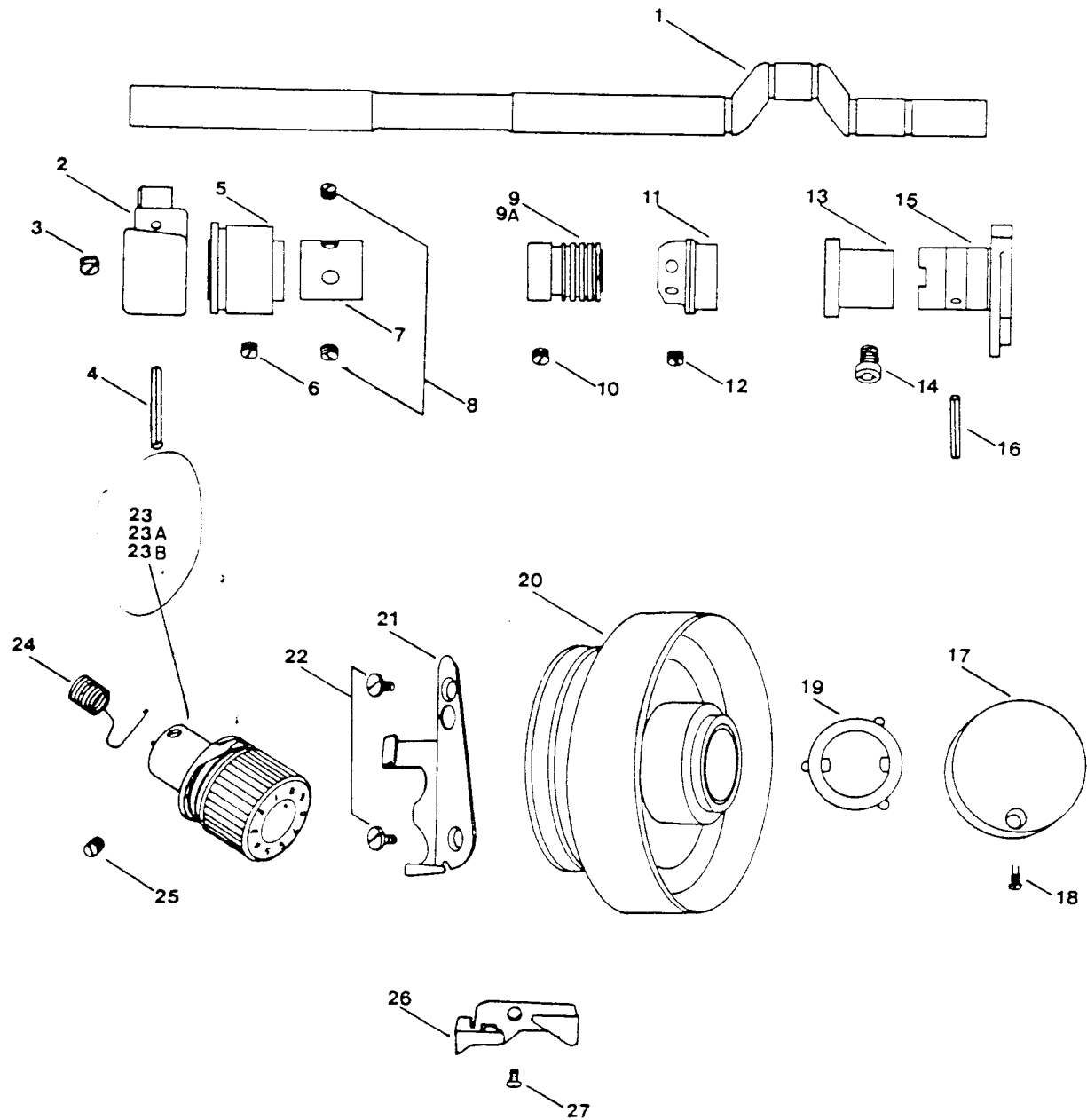

From the library of: Diamond Needle Corp

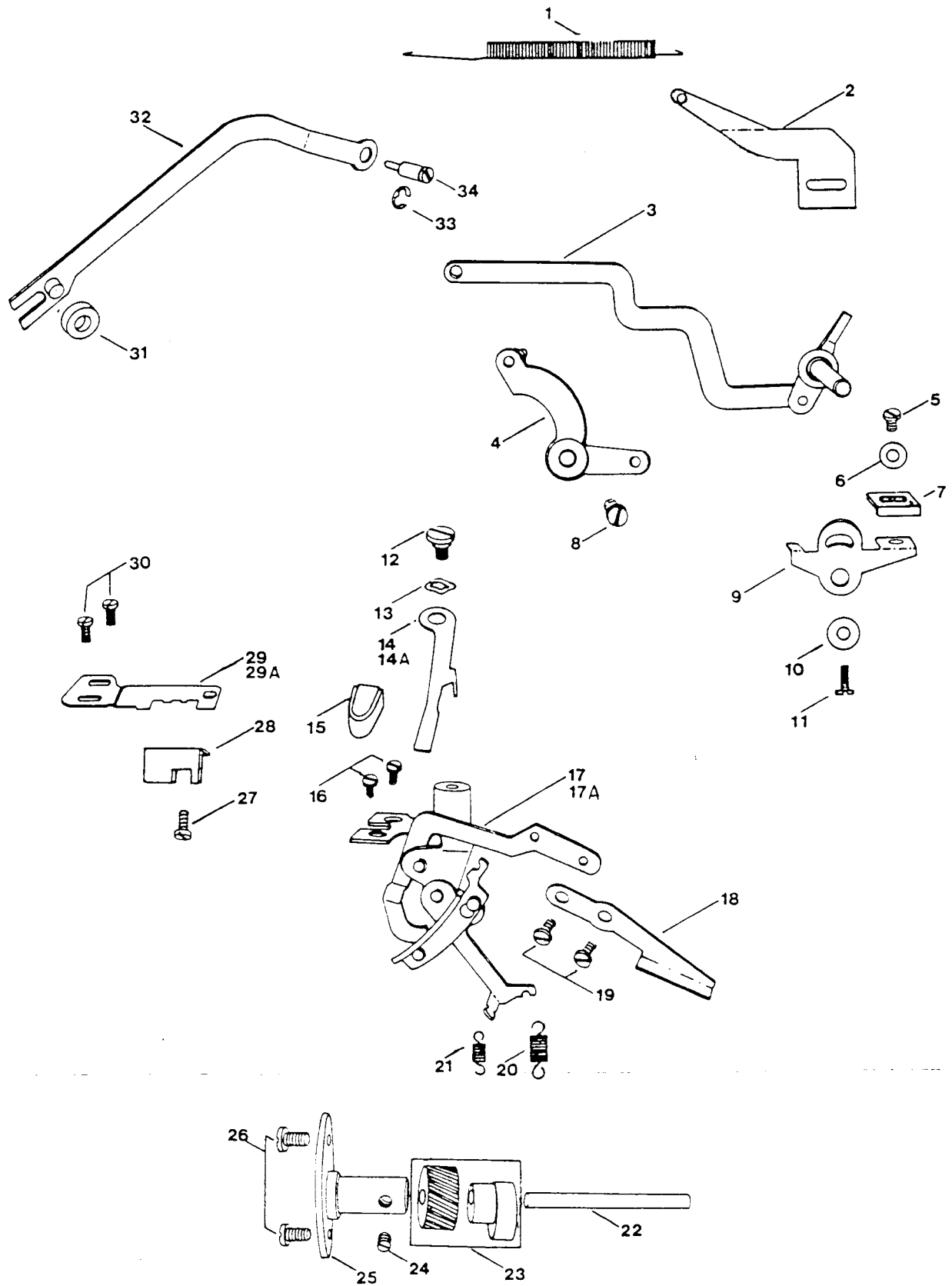

From the library of: Diamond Needle Corp

5100 PARTS LIST

REF.	PART #	CAM CONTROL MECHANISM (A)	5102	5107	5123	5127
1	170538	Cam follower spring				
2	170322	Spring plate			X	
3	170463	Stitch width connecting lever			X	
4	170472	Stitch width crank	X			
5	170469	Set screw	X			
6	170467	Washer	X			
7	170468	Bight position stopper	X			
8	170473	Set screw	X			
9	170464	Stitch width stopper	X			
10	170466	Washer	X			
11	170465	Set screw	X			
12	170478	Set screw	X			
13	170477	Spring washer	X			
14	170475	Needle position lever	X			
14A	170446	Needle position lever			X	
15	170476	Needle position lever knob	X			
16	170448	Set screw	X			
17	170449	Zig-zag mechanism complete	X			
17A	170447	Zig-zag mechanism complete			X	
18	170461	Zig-zag mechanism correct plate	X			
19	170462	Set screw (2)	X			
20	170450	Spring	X			
21	170456	Needle bar oscillating plate spring	X			
22	170459	Cam shaft	X			
23	170452	Bight cam	X			
24	170453	Set screw	X			
25	170454	Plate	X			
26	170455	Set screw	X			
27	170423	Set screw			X	
28	170424	Needle position stopper			X	
29	170471	Needle position plate	X			
29A	170445	Needle position plate			X	
30	170470	Set screw (2)	X			
31	170458	Plastic washer	X			
32	170457	Stitch width needle bar crank lever	X			
33	170559	Snap ring	X	X	X	X
34	170460	Eccentric pin	X			

From the library of: Diamond Needle Corp

5100 PARTS LIST

REF.	PART #	CAM CONTROL MECHANISM (B)	5102	5107	5123	5127
1	170198	Set screw		X		X
2	170194	Buttonhole connecting lever		X		X
3	170197	Reverse stitch connecting plate spring		X		X
4	170196	Snap ring		X		X
5	170195	Connecting plate supporter		X		X
6	170199	Reverse stitch connecting plate		X		X
7	170264	Nut (small)		X		X
8	170263	Nut (large)		X		X
9	170265	Spring		X		X
10	170262	Connecting bar for reverse patterns		X		X
11	170266	Set screw		X		X
12	170267	Feed regulator spring (A)		X		X
13	170280	Feed regulator spring	X	X		X
14	170237	Set screw		X	X	X
15	170236	Zig-zag connecting plate		X		X
16	170239	Spring washer (2)	X	X		X
17	170238	Zig-zag connecting plate		X		X
17A	170240	Washer		X	X	X
18	170241	Pin stud		X		X
19	170242	Nut	X	X		X
20	170200	Needle bar connecting plate		X		X
21	170201	Set screw		X		X
22	170460	Eccentric pin	X			
23	170211	Snap ring	X			
24	170516	Connecting link screw			X	
25	170530	Washer			X	
26	170517	Nut			X	
27	170531	Snap ring			X	
28	170474	Cam follower connecting link			X	
29	170189	Needle bar oscillating plate		X		X
30	170191	Ndle. bar oscillating correcting pl. spring		X		X
31	170237	Set screw		X	X	X
32	170193	Adjusting screw		X		X
33	170192	Adjusting nut		X		X
34	170187 †	Oscillating plate fitting plate		X		X
35	170188	Set screw (2)		X		X
36	170190	Snap ring		X		X

From the library of: Diamond Needle Corp

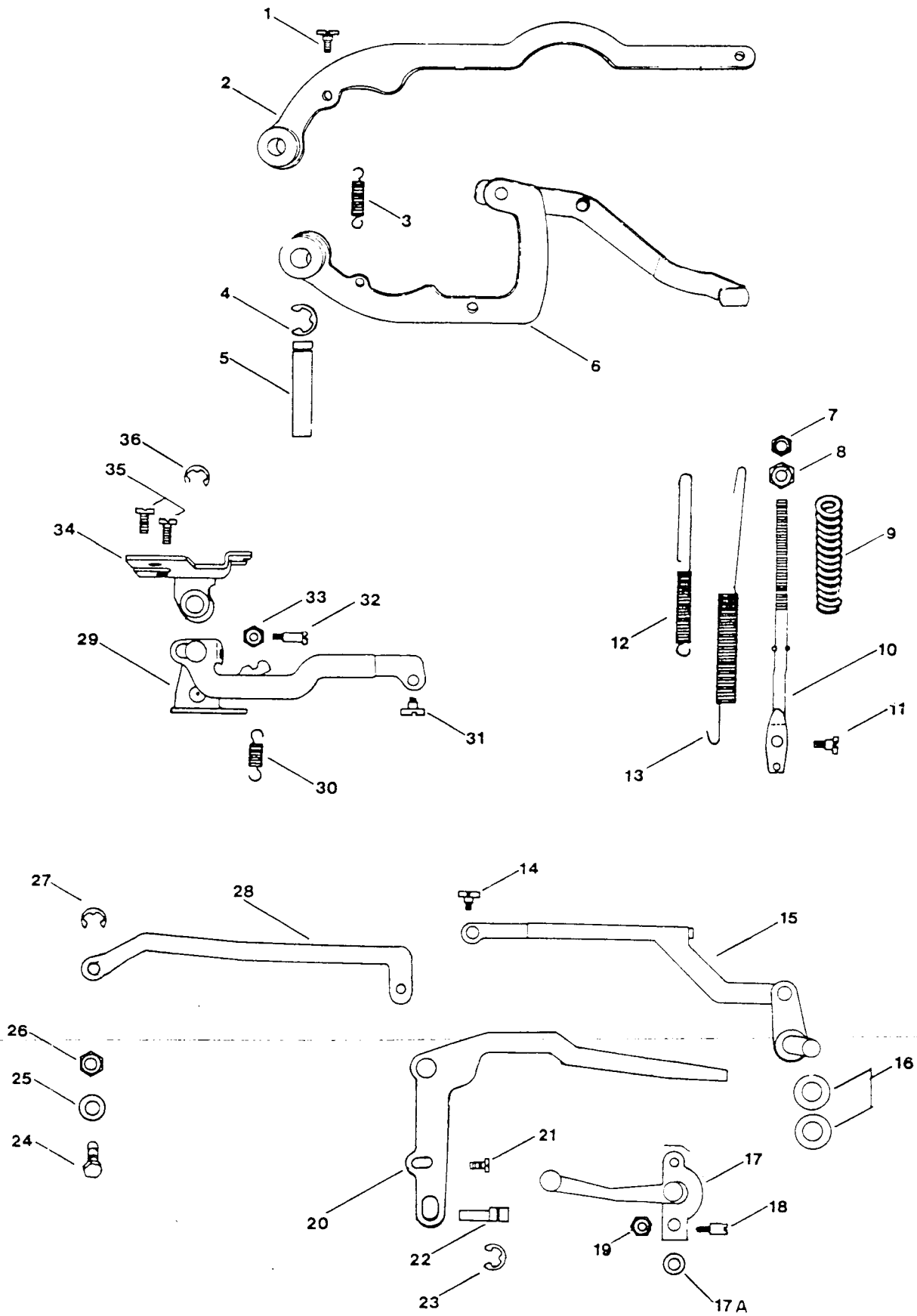

From the library of: Diamond Needle Corp

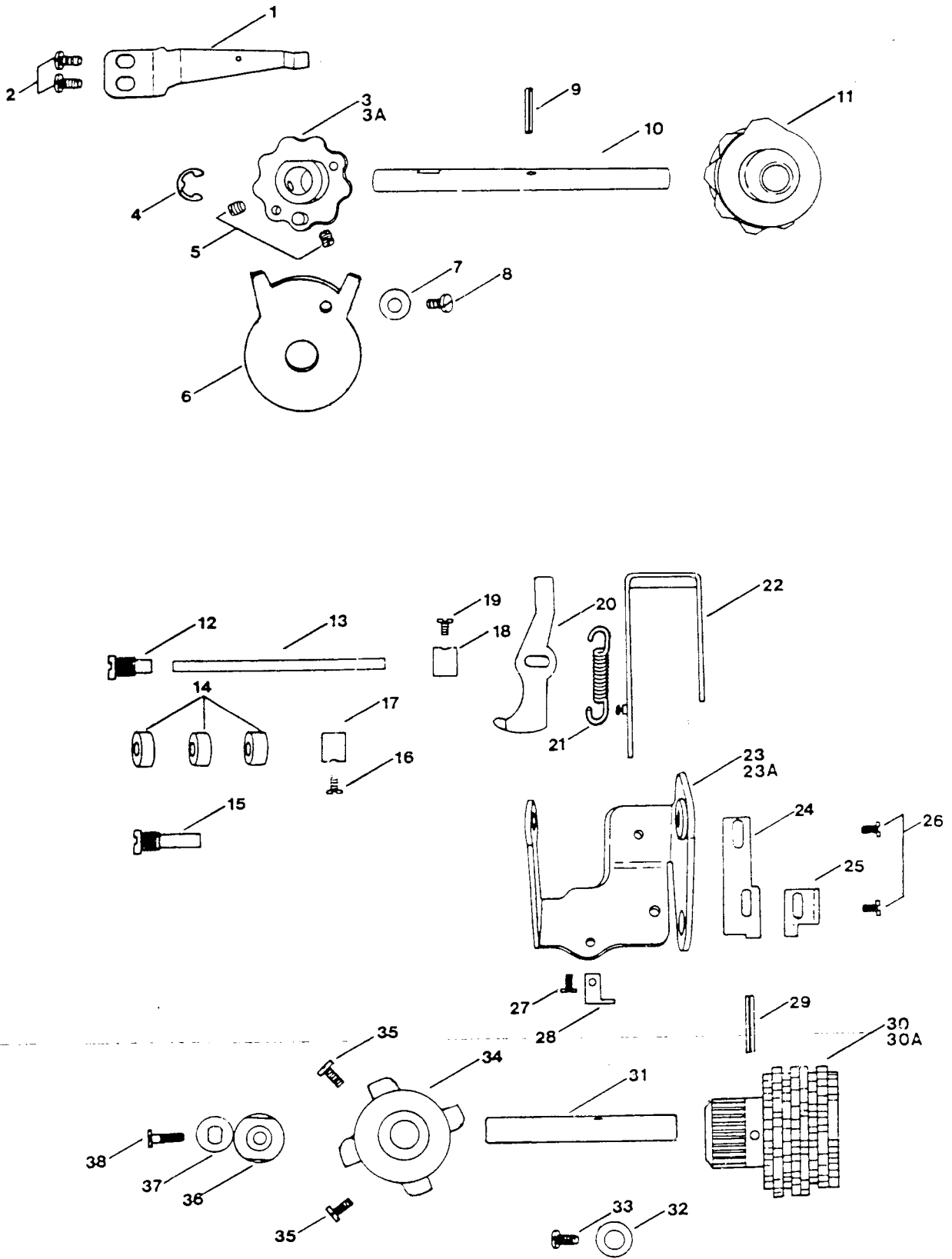

From the library of: Diamond Needle Corp

5100 PARTS LIST

REF.	PART #	CAM CONTROL MECHANISM (C)	5102	5107	5123	5127
1	170202	Detent spring		X		X
2	170203	Set screw (2)		X		X
3	170224	Pattern detent plate		X		(X)
3A	170529	Pattern detent plate			X	
4	170451	Snap ring	X			
5	170225	Set screw (2)		X		X
6	170532	Straight stitch position stopper			X	
7	170534	Stopper washer			X	
8	170533	Stopper screw			X	
9	170229	Pattern cam selector shaft pin		X		X
10	170223	Shift cam shaft		X		X
11	170228	Pattern cam selector		X		(X)
12	170221	Set screw		X		X
13	170219	Cam follower shaft		X		X
14	170537	Collar (3)			X	
15	170218	Cam follower shaft screw		X		X
16	170536	Collar screw			X	
17	170537	Collar			X	
18	170220	Cam follower shaft stop collar		X		X
19	170536	Set screw		X		X
20	170217	Cam follower		X	X	X
21	170222	Cam follower spring		X		X
22	170216	Cam follower supporting bracket		X		X
23	170206	Pattern cam device bracket		X		X
23A	170342	Pattern cam device bracket			X	
24	170212	Bight position stopper (larger)		X		X
25	170214	Bight position stopper (small)		X		X
26	170213	Set screw (2)		X		X
27	170210	Set screw		X		X
28	170209	Spring plate		X		X
29	170231	Pattern cam shaft pin		X		X
30	170230	Pattern cam			X	
30A	170528	Pattern cam		X		(X)
31	170235	Pattern cam shaft		X		X
32	170208	Washer		X		X
33	170207	Set screw		X		X
34	170226	Flexi cam ✓		X		X
35	170227	Set screw (2)		X		X
36	170234	Flexi cam shaft collar		X		X
37	170233	Adjusting washer		X		X
38	170232	Set screw		X		X

From the library of: Diamond Needle Corp

5100 PARTS LIST

REF.	PART #	ELECTRICAL EQUIPMENT	5102	5107	5123	5127
1		Brush cap	X	X	X	X
2		Brush cap insert	X	X	X	X
3		Brush with spring	X	X	X	X
4		Set screw	X	X	X	X
5		Motor pulley	X	X	X	X
6		Washer	X	X	X	X
7		Nylon spacer	X	X	X	X
8		Nylon washer	X	X	X	X
9		Nut	X	X	X	X
10		Motor mounting bracket	X	X	X	X
11	988215-001	Motor (120 Volt)	X	X	X	X
11	988217-001	Motor (120 Volt) (Alternate)	X	X	X	X
11	988217-002	Motor (220 Volt)	X	X	X	X
11	988217-003	Motor (240 Volt)	X	X	X	X
12	170437	Motor belt	X	X	X	X
13	170439	Motor set screw washer	X	X	X	X
14	170438	Motor set screw spring washer	X	X	X	X
15	170440	Motor set screw	X	X	X	X
16	170436	Cord grommet	X	X	X	X
17	988216-001	Controller (120 Volt) <i>Be-volt</i>	X	X	X	X
17	988218-001	Controller (120 Volt) (Alternate)	X	X	X	X
17	988295-001	Controller (120 Volt) Canada	X	X	X	X
17	988218-002	Controller (220 Volt)	X	X	X	X
17	988218-003	Controller (220 Volt)	X	X	X	X
17	988218-004	Controller (240 Volt)	X	X	X	X
17	988218-005	Controller (240 Volt)	X	X	X	X
18	170422	Lamp	X	X	X	X
19	170421	Lamp cord complete	X	X	X	X
20	170414	Set screw (2)	X	X	X	X
21	170415	Washer (2)	X	X	X	X
22	170412	Nut (2)	X	X	X	X
23	170416	Set screw	X	X	X	X
24	170413	Lamp bracket	X	X	X	X
25	170430	Lamp cord guide set screw	X	X	X	X
26	170429	Lamp cord guide	X	X	X	X
27	170435	Set screw (2)	X	X	X	X
28	170434	Receptacle	X	X	X	X
29	170433	Receptacle insulation	X	X	X	X
30	170427	Terminal bracket	X	X	X	X
31	170428	Set screw (2)	X	X	X	X

SEE: TABLE OF TERRITORIES FOR MOTORS AND CONTROLLER

